

REVISION HISTORY			
REV	DESCRIPTION	DATE	APPROVED

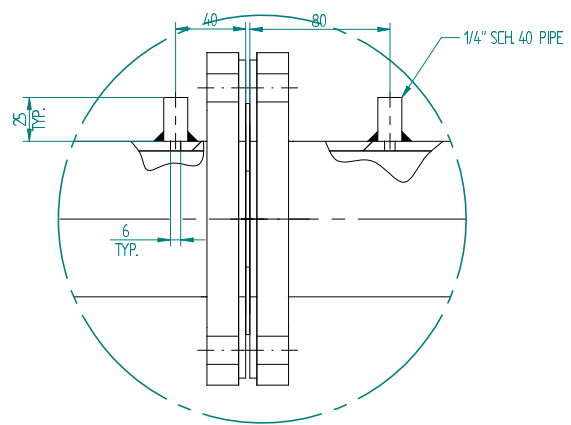

DETAIL A

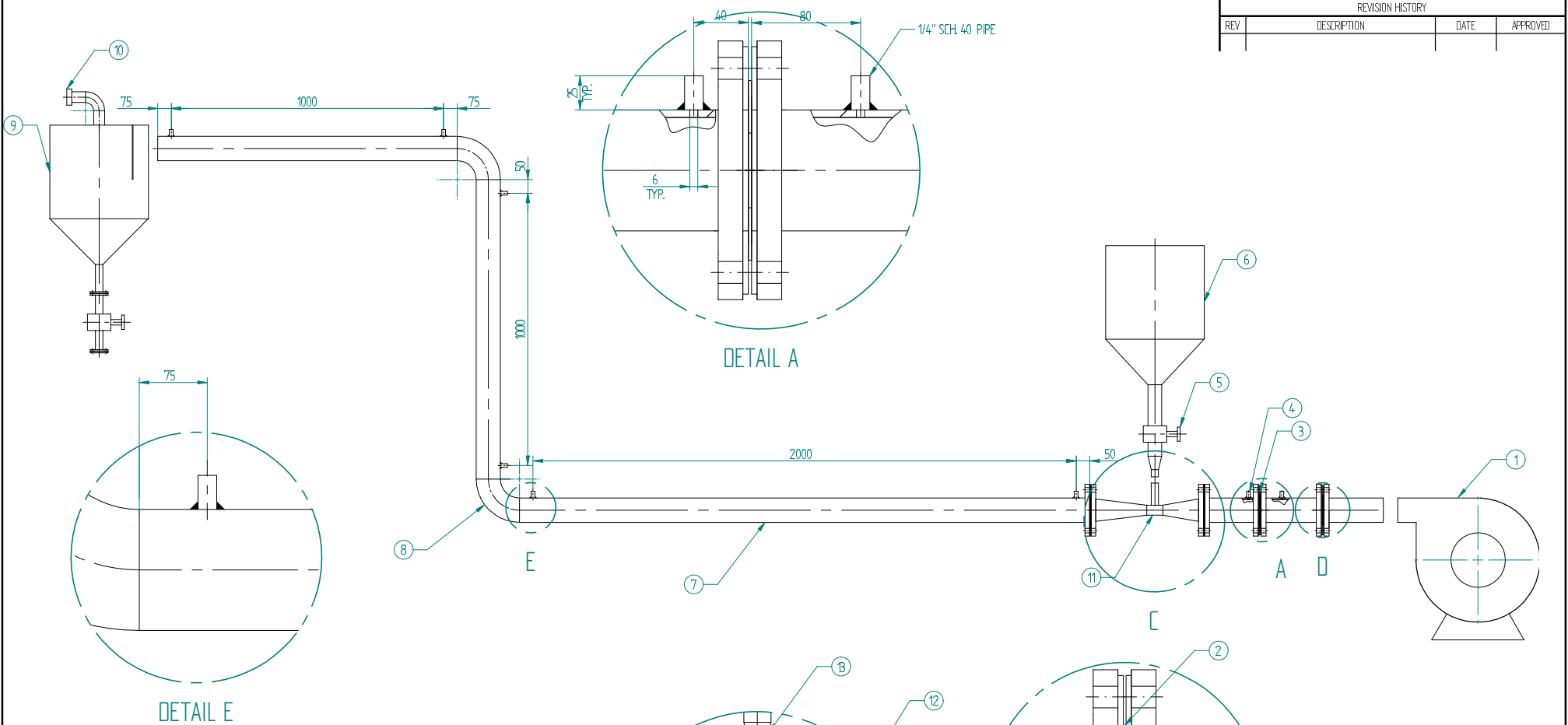
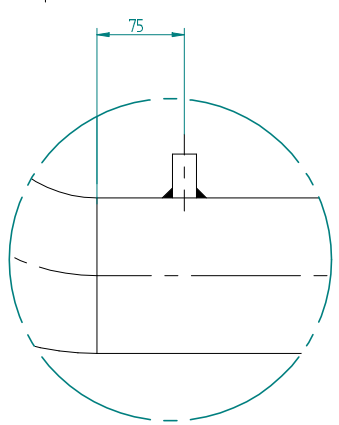

DETAIL E

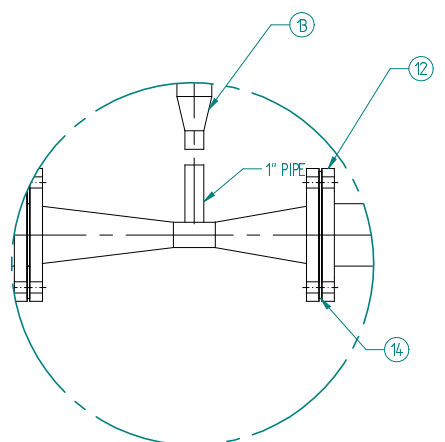

DETAIL C

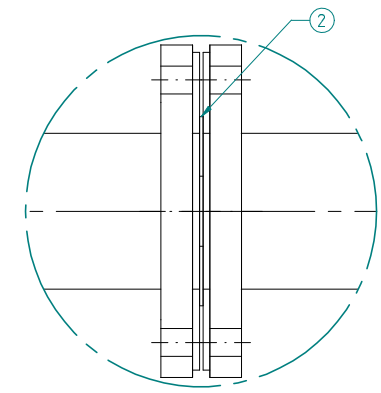

DETAIL D

PART NO.	NAME	SPECIFICATION	QTY.	REMARK
14	GASKET	3" FLANGE	6	-
13	REDUCER	2" TO 1"	1	-
12	STANDARD FLANGE	FOR 3" PIPE	8	-
11	VENTURI FEEDER	SHEET 5 OF 5	1	FLUX FEEDER
10	FILTER	-	1	-
9	SEPARATOR	-	1	-
8	ELBOW	90 DEG.	2	L. R. ELBOW
7	PIPE	3" SCH. 40 PIPE	1	CONVEYING PURPOSE
6	FEEDING BIN	-	1	-
5	BUTTERFLY VALVE	-	1	FLUX FLOW CONTROL
4	PRESSURE TAPPING	1/4" SCH. 40 PIPE	8	PRESS. MEASUREMENT
3	ORIFICE PLATE	SHEET 4 OF 5	1	FLOW MEASUREMENT
2	ORIFICE PLATE	SHEET 3 OF 5	1	PRESSURE REDUCER
1	BLOWER	450 m ³ /hr, 2900 mmWC	1	POSITIVE PRESSURE
PART LIST				

NAME	DATE	SOLID EDGE	
DRAWN: DAS	02/28/08	L.A. HAZELBANKS	
CHECKED:		UGS - The PLW Company	
ENG. APPR:		GENERAL ASSEMBLY DRAWING	
MGR. APPR:		OF	
		TEST SETUP	
UNLESS OTHERWISE SPECIFIED DIMENSIONS ARE IN MILLIMETERS ANGLES =XX°		SIZE: A2	REV: 0
2 PL. =XXX 3 PL. =XXXX		FILE NAME: TEST SETUP LAYOUT.dwg	
SCALE:	WEIGHT:	SHEET 5 OF 5	