

Zentralkette

für Hochleistungsbecherwerke

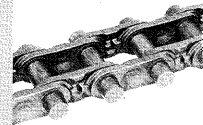
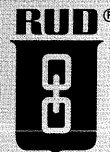

Central-Chain

for high output bucket elevators

Zentralkette
Montageanleitung/Betriebshinweise
Central-Chain
Assembly instructions

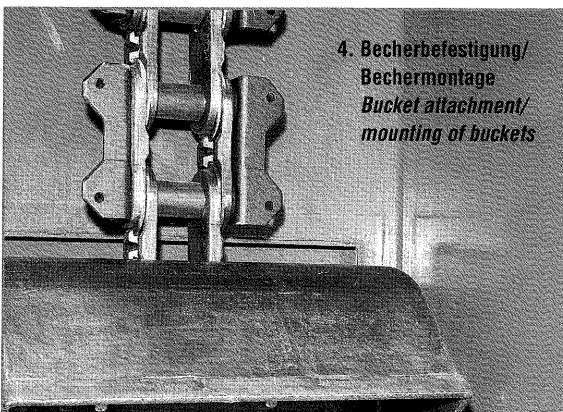
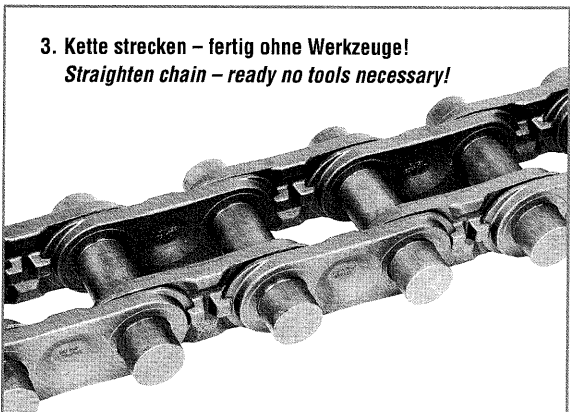
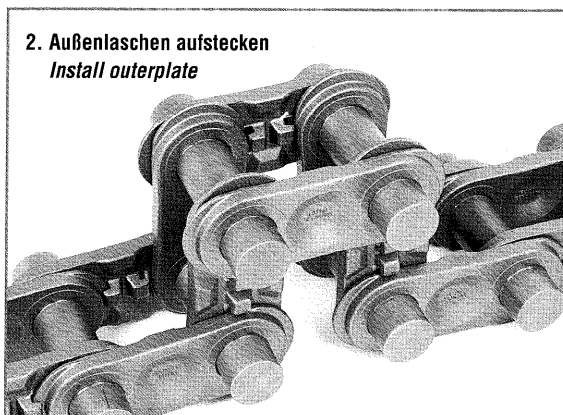
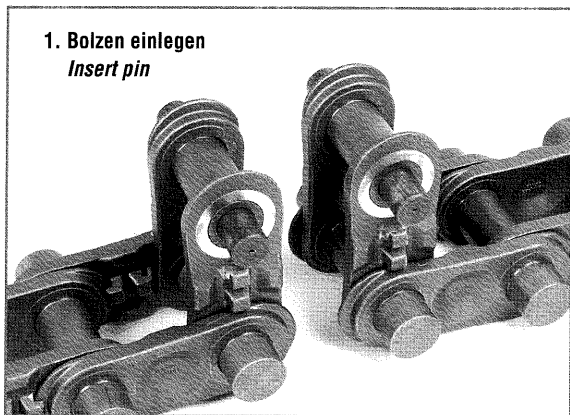

Montage/Demontage

Montage:

- Die Kette kann durch einfaches Abwinkeln der Kettenlieder an jeder Stelle **ohne Werkzeuge** leicht geöffnet, verkürzt oder verlängert werden.
- Montagefreundlich.

Kette ist wendbar

- Größeres Verschleißvolumen.
- Größere Standzeit.

Beachten:

- Winkel in Pfeilrichtung spielfrei montieren.

Mounting/Dismounting

Mounting:

- By pivoting the individual link, the chain can be disassembled, shortened or extended at each joint **without tools**.
- Simple mounting and dismounting.

Chain can be turned 180°

- Larger wear volume.
- Increased life time.

Attention:

- Mount the bucket attachments in the direction of the arrows without gap.

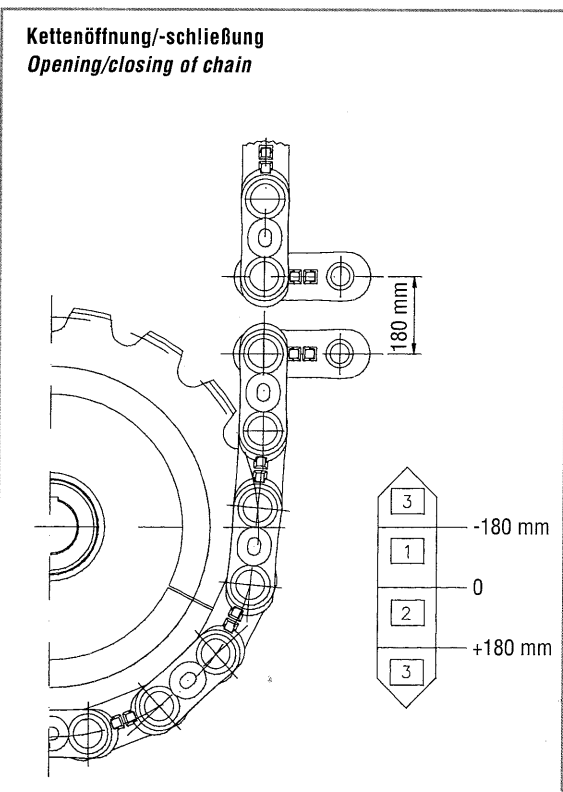
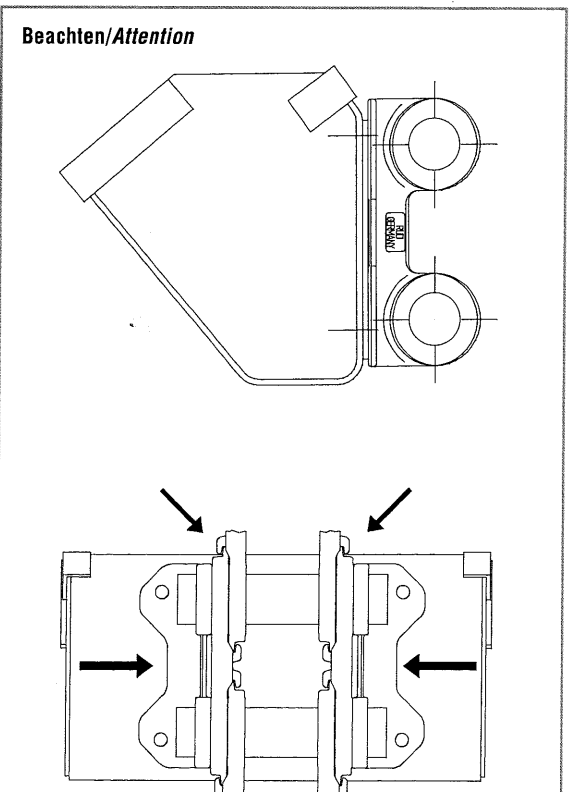

Datenblatt für Verschleißmessung bitte separat anfordern.

Data sheet for wear-measuring request please separatly.