

Used equipment for sale by Intercem

Used|refurbished crusher 'MIAG 68 D 90' ; IC#I00177

Special opportunity: Intercem offers a used and refurbished double shaft hammer crusher preferably to be used as primary crusher in limestone quarries. Main technical data: Double rotor hammer crusher with reduction gear; Design capacity approx. 500 t/h < 25 mm. Documentations, drawings, certificates of origin are available.

Scope of supply:

- Maximum edge length of feed: 1500 mm
- Maximum weight of feed: 2000 kg
- Feed material at site: Limestone - middle hard
- Maximum humidity: Approx. 4 - 6 %
- Bulk density of feed: Approx. 1,5 t/m
- Capacity: Approx 500 t/h at site
- Product size: < 25 mm
- Year of construction: 1971

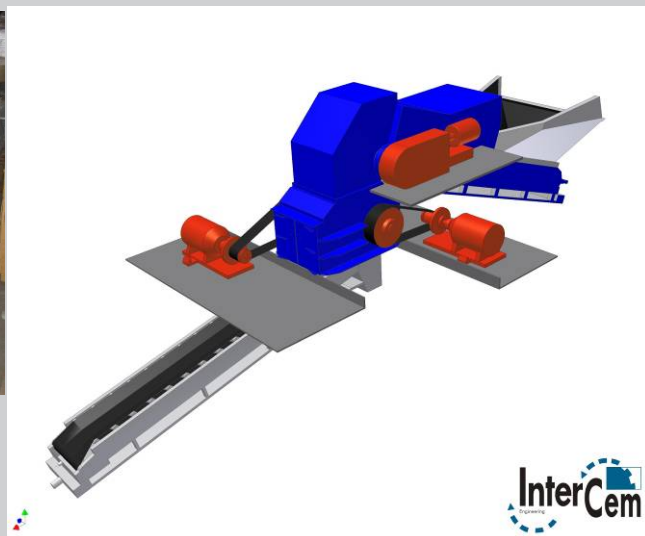

In case of Interest please contact:

Mr. Tim Hücking, tel. +49 2522 92058-17, t.huecking@intercem.de

Intercem Engineering GmbH
 Carl-Zeiss-Str. 10
 59302 Oelde, Germany
 Phone: +49 2522 92058-0
 Fax: +49 2522 92058-20
www.intercem.de

Intercem Engineering is a leading company for the supply of used and new equipment for the cement industry. Turn key plants are either designed as combination of used and –as far as necessary- new equipment. A high-class team of engineers provides comprehensive engineering for technology and design also for complete new production lines. If you are interested the o. m. component could be implemented in a comprehensive solution.



