



1. General

A pilot operated start-unloading valve allows for the blower to start up in an unloaded condition, and it allows the user to set a maximum operating pressure not to be exceeded. It is generally used where more than one blower is connected to a common discharge header, each blower package being equipped with its own discharge check valve, and it may be common to occasionally, or even consistently encounter pressure spikes in the air pipe.

In absence of a start-unloading valve, the motor has to start the blower and to drive it up to its operating speed against the line pressure.

While starting, a squirrel cage induction motor typically draws 6 to 7 times its nominal current. To reduce this current peak, one can choose between several types of motor starters that start the motor at reduced voltage.

The most common type is the Y / Δ starter. While starting in the “Y” position, the starting torque of the motor is reduced to approximately 30 % of the full voltage starting torque.

By using a start-unloading valve, the blower can be started unloaded, allowing the motor to bring it to speed with reduced torque while in the “Y” position of the starter.

The starting torque for the fully unloaded blower amounts typically to approximately 5 – 10 % of the operating torque.

Once the pilot valve is set to the not to be exceeded header pressure the AEROPRESS will automatically blow-off any excess air and maintain the set pressure. It is designed to handle the full air volume of the blower and can safely allow continuous blower operation in the event the blower package is operated with a fully closed discharge air pipe.

In its standard design (without solenoid valve), the AEROPRESS start-unloading valve operates completely independent & without any electrical requirement.



Aerzen USA Corporation

108 Independence Way, Coatesville, PA 19320
 Tel: (610) 380-0244 Fax: (610) 380-0278
www.aerzenusa.com

AEROPRESS – Start / Unloading and Pressure Regulating Valve for Rotary Positive Displacement Blowers

Date	Doc #	Page
06/25/08	B-6-0209 revision “-”	1 of 4

2. Installation of the AEROPRESS

The AEROPRESS is to be installed between the check valve and the blower. On all Aerzen packages, the AEROPRESS has been installed at the correct location. A 750 mm (»2.4 ft. long) hose and a G 3/8" male thread fitting are supplied with the valve for the control pressure connection of the pilot valve. The connection is made to sense the main process piping system pressure. All of the AEROPRESS valves come with metric flange connections (DN-80, 150 or 200 depending on the model). Optional flange connections may be available – please contact Aerzen After-Sales / Service for details.

The valve may be installed in any orientation except flange side up.

Before start up, remove any shipping/packaging materials.

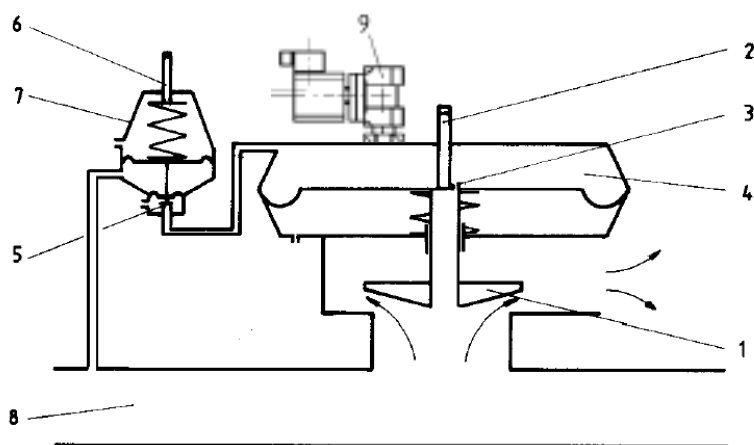

1. housing / valve seat
2. unloading valve adjustment spindle
3. spindle with nozzle
4. diaphragm
5. pilot valve seat
6. pilot valve adjustment screw
7. pilot valve
8. process piping
9. solenoid

3. Operation without solenoid valve (standard)

a) Unloading valve function

The unloading valve is a normally open device. Thus when the blower is started, the discharge air of the blower is diverted from the process piping (due to the closed check valve) through the unloading valve and out the vent opening. As the air flows through the valve a small amount of air travels up the spindle (3) pressurizing the top of the diaphragm (4). Ultimately the force resulting from the pressure on the diaphragm overcomes the spring force and the valve (1) closes, diverting the blower airflow back to the process piping. NORMAL CLOSING TIME 30-35 SECONDS.

b) Pressure control function

Once the unloading valve is closed, air is being conveyed into the process piping (8). The installed pilot valve pressure sensing line delivers the process piping pressure to the pilot valve (7). The adjusting screw (6) sets the set pressure of the pilot valve seat (5). Once the process pipe pressure overcomes the pilot valve set pressure, the valve seat (5) lifts and allows air from the diaphragm (4) area to escape through the pilot valve vent. This continues to happen until equilibrium is reached between the pilot valve set pressure and the diaphragm area pressure.



Aerzen USA Corporation

108 Independence Way, Coatesville, PA 19320
Tel: (610) 380-0244 Fax: (610) 380-0278
www.aerzenusa.com

AEROPRESS – Start / Unloading and Pressure Regulating Valve for Rotary Positive Displacement Blowers

Date	Doc #	Page
06/25/08	B-6-0209 revision “-”	2 of 4

4. Operation with solenoid valve (optional)

Operation of this system is the same as the “standard”, except that a solenoid valve (9) is installed, venting the top of the diaphragm, keeping the unloading valve open as long as the solenoid valve remains open. This allows the blower to run unloaded for a longer period at start-up as well as allowing the unloading cycle to be controlled by an electrical signal from the operator.

The standard solenoid valve (9) is normally closed, thus requiring electric current to energize the coil and open the solenoid valve, venting the top chamber of the valve allowing the AEROPRESS valve to open. An optional normally open valve can also be purchased, however the reason for the normally closed version is in case of failure of the solenoid valve (valve fails closed) the AEROPRESS would still function as a “standard” unit.

5. Maintenance

The AEROPRESS unloading valve does not require any particular maintenance. It is important to make sure that the discharge opening is unobstructed with foreign material or paint.

Should the unloading device not close after correct adjustment, the nozzle (5) may need to be cleaned (refer to sectional drawing to disassemble unit) remove and blow out with compressed air.

6. Adjusting the closing time of the AEROPRESS

The valves are shipped set up for maximum closing time. However if they need to be adjusted, in order to obtain the sufficient ΔP for the valve to operate properly (pressure drop across the valve should be between 2 psi and 1/3 of the normal operating pressure). After this initial adjustment the valve will operate automatically without any further manipulation. Follow this procedure for adjustment:

- a) **Attention!** Paying attention to the starting frequency of the drive motor. Also, due to safety reasons adjustments must only be done when the motor is switched off!
- b) Remove the discharge plenum for units within sound enclosures.
- c) The closing process can be detected by the noise of the air escaping from the unloading device or by monitoring the discharge pressure gauge.
- d) If necessary an adjustment can be made to the closing time. This can be done set by loosening the lock-nut holding the spindle (2) and moving the spindle:
 - spindle (2) clockwise closing time is decreased
 - spindle (2) counter-clockwise closing time is increased
- e) After the adjustment, tighten the lock-nut.
- f) After resetting the unloading device, all loosened and disassembled parts are to be re-attached and secured properly.



Aerzen USA Corporation

108 Independence Way, Coatesville, PA 19320
Tel: (610) 380-0244 Fax: (610) 380-0278
www.aerzenusa.com

AEROPRESS – Start / Unloading and Pressure Regulating Valve for Rotary Positive Displacement Blowers

Date	Doc #	Page
06/25/08	B-6-0209 revision “-”	3 of 4

7. Adjusting the set pressure of the AEROPRESS pilot valve

Remove the black plastic cap. The required system pressure maybe set by turning the adjusting screw of the pilot valve with a screwdriver (see picture below) upon loosening its locknut. After reaching the desired set pressure, tighten the lock nut and replace the cap. AEROPRESS valves are shipped with un-adjusted pilot valves and need to be field set. The set pressure is set to the minimum.



**Increase
set pressure**

**Decrease
set pressure**

8. Performance

Type	Air flow CFM	Delta P at Qmax (PSI)	Temp range °F		P range PSI		Weight in lbs	Flange	Aerzen Part Number
			min	max	min	max			
2	71 - 424	4	5	266	2.0	15	9.0	G2" threaded	91-0004-02-G2
2	71 - 424	4	5	266	2.0	15	9.7	square 150mm / 6"	91-0004-02-SQ
3	353 - 883	3	5	266	2.0	15	9.0	G3" threaded	91-0004-03-G3
3	353 - 883	3	5	266	2.0	15	10.4	square 150mm / 6"	91-0004-03-SQ
4	706 - 1766	3	5	266	2.0	15	18.1	G4" threaded	91-0004-04-G4
4	706 - 1766	3	5	266	2.0	15	18.7	square 150mm / 6"	91-0004-04-SQ
4	706 - 1766	3	5	266	2.0	15	20.3	DN100	91-0004-04-DN100



Aerzen USA Corporation

108 Independence Way, Coatesville, PA 19320
Tel: (610) 380-0244 Fax: (610) 380-0278
www.aerzenusa.com

AEROPRESS – Start / Unloading and Pressure Regulating Valve for Rotary Positive Displacement Blowers

Date
06/25/08

Doc #
B-6-0209 revision “-”

Page
4 of 4