

# Vertical single-shaft mixer

patented

**Ideal mixing quality for dry, moist and viscous materials at variable filling levels**

*For materials with explosive dust, tip speed less than 1 m/s!*

The spiral mixing blade initiates a three-dimensional flow of the mixing goods. The mixer can be designed to conform with FDA-standards to be used as a sterile mixer and reactor which also meets EHEDG requirements and the 3-a-sanitary standards.

Kwick-Klump®

Gear box covered by stainless steel on request

SinConcave® spiral blade (patented) driven and supported from above with the advantage of complete discharge

Liquid lance sprays into the active chopper area

Choppers to improve the mixing process by deagglomeration

Inspection door without dead space designed by Clever-Cut®

Rotational washing nozzles, dismantlable via sanitary flanges

Discharge flap without dead space

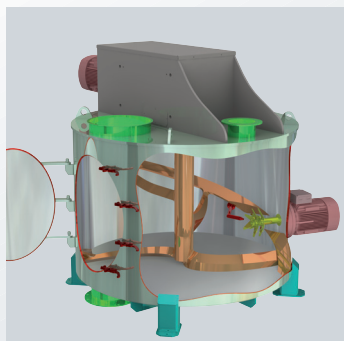

On request different designs are available, such as slim or low profiled mixing chambers



**New!**

SinConvex® spiral blade (patented), meets the sine curve, creating ideal mixing qualities and best discharge ability



Model VM 2500

## Vertical single-shaft mixer, Model VM

Model	ca. dimensions in mm, ca. weight in kg					Weight
	A	B	C	D	E	
100	350	600	1200	600	145	560
200	420	750	1300	750	145	680
300	450	700	1400	880	145	720
400	450	880	1400	880	145	800
500	450	800	1550	1000	145	1040
600	480	1000	1700	1000	145	1200
800	500	950	1850	1180	145	1440
1000	550	1180	1900	1180	145	1600
1500	600	1350	2200	1350	145	2560
2000	700	1490	2300	1490	145	3040
2500	730	1530	2400	1530	145	2960
3000	750	1710	2600	1710	145	3360
4000	750	1870	2900	1870	145	4240
5000	850	2010	3200	2010	145	5840
6000	850	2150	3200	2150	145	6240
7000	900	2050	3400	2400	145	6800
8000	900	2370	3400	2370	145	7600
9000	1000	2000	3750	2800	145	8000
10000	1100	2200	4100	2800	145	8800
12000	1100	2500	4100	2800	145	10400
15000	1100	3100	4400	2800	145	12000
17000	1250	2800	4500	3170	145	13600
20000	1500	2700	4800	3430	145	16000
25000	1600	3550	5100	3430	145	20800
30000	1600	4120	5100	3430	145	24800
40000	1600	4250	5300	3820	145	33600

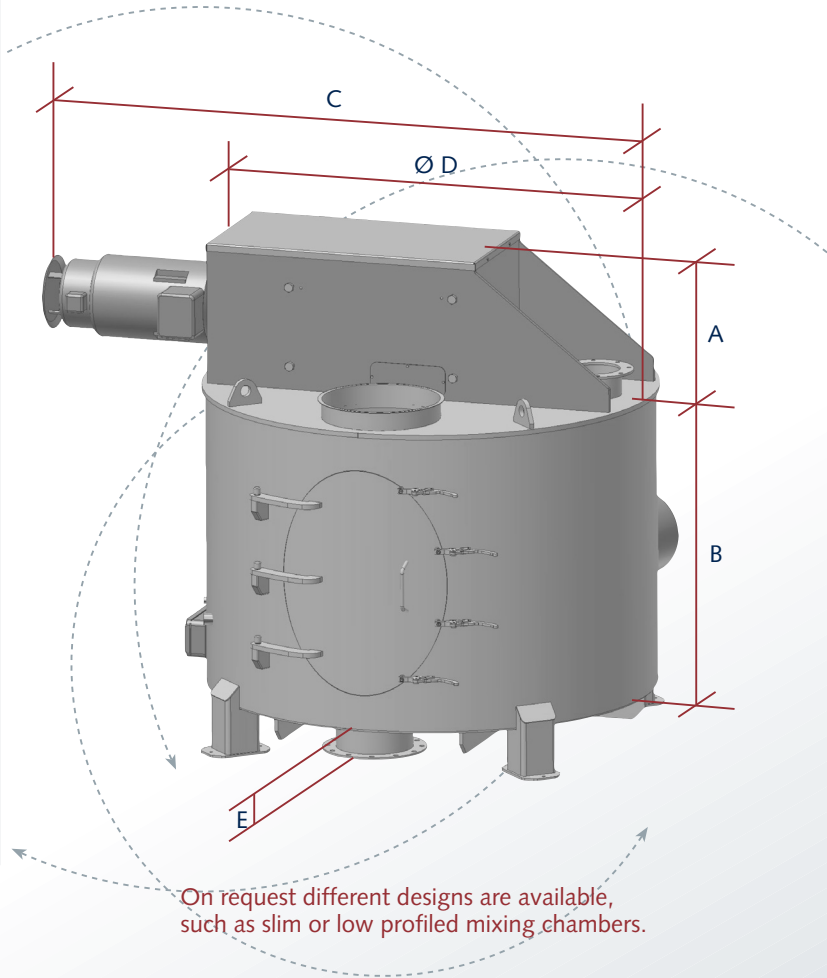

Interim sizes are offered in 100 litre steps. Bigger mixers up to 50 000 litres are available on demand. Depending on the user needs the mixer weight may be lower or higher. Please ask for individual dimension sheets.

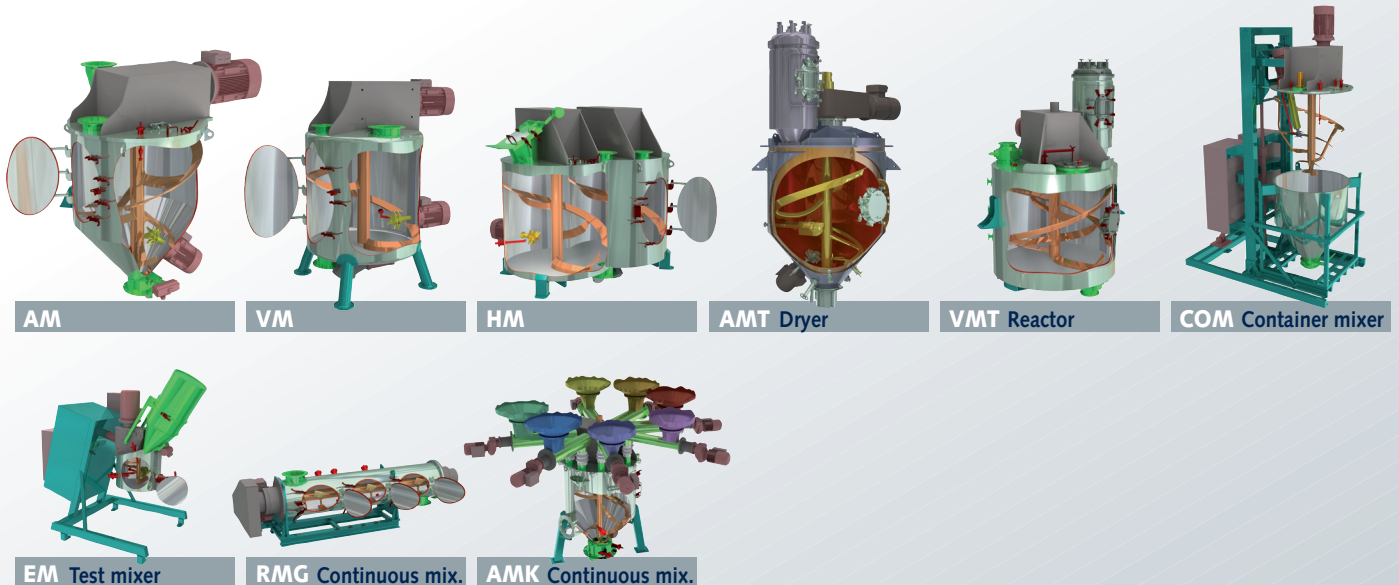

amixon® test laboratories are available in Paderborn, Germany, in Memphis, USA and in Osaka, Japan. On request amixon can prepare detailed qualification documents.

We reserve the right to make changes due to progress in process engineering and manufacturing technology.  
© by amixon GmbH, Paderborn. Reprinting or transfer to electronic media only permitted after written approval.

amixon® GmbH

Halberstädter Straße 55  
D-33106 Paderborn (Germany)

Phone +49 (0) 52 51 / 68 88 88-0  
Fax +49 (0) 52 51 / 68 88 88-999  
e-mail info@amixon.de

www.amixon.com