

Vacuum-mixer dryer, Reactor

patented

Very gentle vacuum-drying at fast reaction rate for dry, moist and viscous materials at variable filling levels

For materials with explosive dust, tip speed less than 1 m/s!

The spiral mixing blade initiates a three-dimensional flow of the mixing goods; creating a spiral upward movement on the periphery and downward flow in the centre. The reactor is vacuum and pressure tight and heatable by steam, thermal oil or water. Fully temperature controlled: the mixing vessel, the mixing arms, the spiral blade.

The mixer can be designed to conform with FDA-standards to be used as a sterile mixer and reactor which also meets EHEDG requirements and the 3-a-sanitary standards.

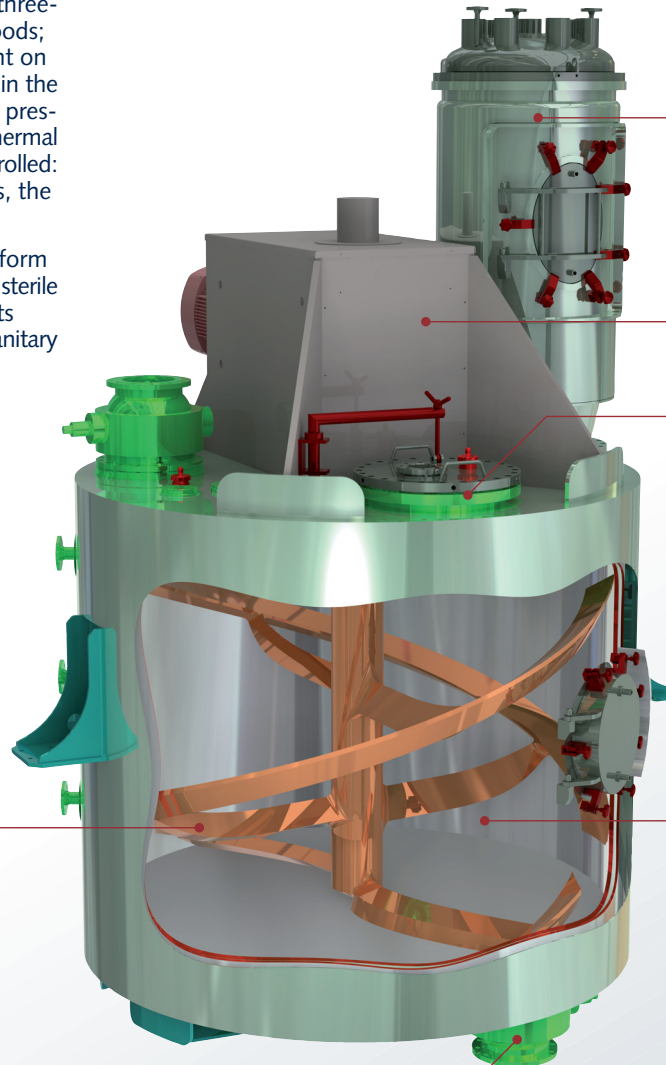

Vapour filter equipped with inspection door on request

Gear box equipped with a cooling device

Man hole can be located on the top or on the side

Rotational washing nozzles, dismantable via sanitary flanges

Choppers can improve the drying process by deagglomeration

SinConcave® spiral blade (patented) driven and supported from above with the advantage of complete discharge

Discharge armature



New!

SinConvex® spiral blade (patented), meets the sine curve, creating ideal mixing qualities and best discharge ability



VMT 2000 Sterile reactor made from Alloy 59 (2.4605)

Vacuum-mixer dryer, Reactor, Model VMT

Model	ca. dimensions in mm, ca. weight in kg					Weight
	A	B	C	D	E	
100	450	600	1300	750	170	1250
200	520	750	1400	900	170	1550
300	550	700	1500	1030	170	1650
400	550	880	1500	1030	170	1800
500	550	800	1650	1150	250	2350
600	580	1000	1800	1150	250	2700
800	600	950	1950	1330	250	3250
1000	650	1180	2000	1330	250	3600
1500	700	1350	2300	1500	250	5750
2000	800	1490	2400	1650	250	6850
3000	900	1710	2700	1850	250	7550
4000	900	1870	3000	2000	250	9550
5000	1000	2010	3300	2150	320	11000
6000	1000	2150	3300	2300	320	14050
7000	1050	2050	3500	2550	320	15300
8000	1050	2370	3500	2500	320	17100
9000	1150	2000	3850	2950	320	18000
10000	1250	2200	4200	2950	320	19800
12000	1250	2500	4200	2950	320	23400
15000	1250	3100	4500	2950	320	27000
17000	1400	2800	4600	3300	320	30600
20000	1650	2700	4900	3550	320	36000
25000	1750	3550	5200	3550	320	46800

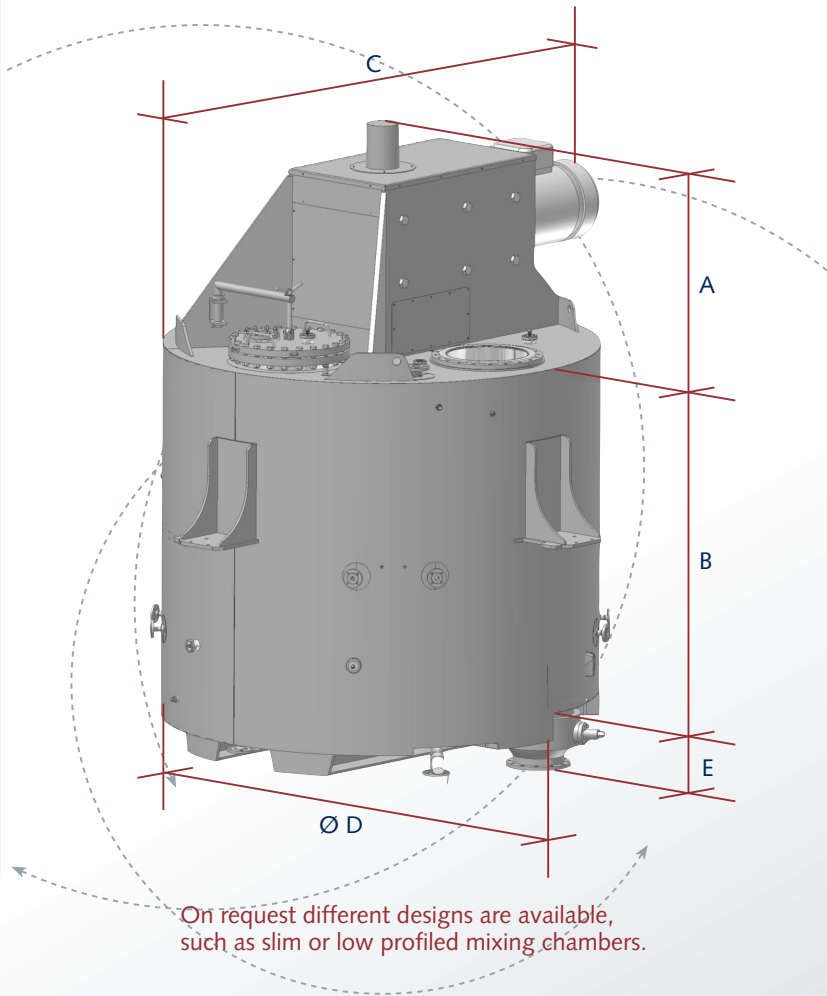

Interim sizes are offered in 100 litre steps. Bigger dryers up to 50 000 litres are available on demand. Depending on the user needs the mixer weight may be lower or higher. Please ask for individual dimension sheets.

On request different designs are available, such as slim or low profiled mixing chambers.

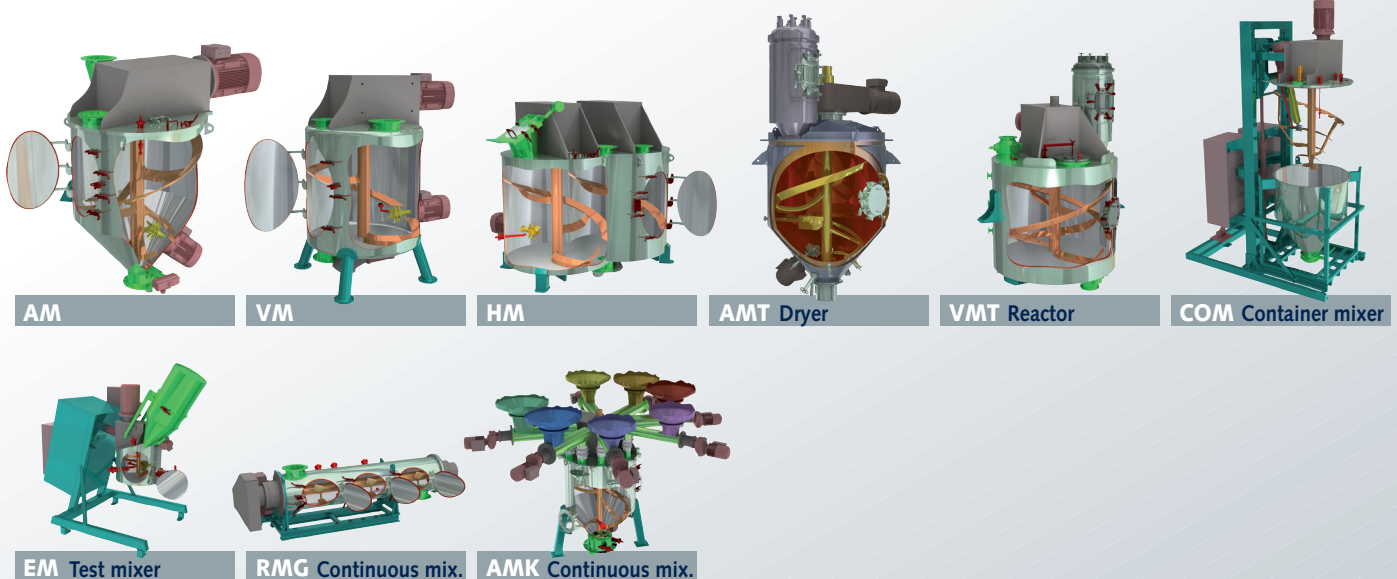

amixon® test laboratories are available in Paderborn, Germany, in Memphis, USA and in Osaka, Japan. On request amixon can prepare detailed qualification documents.

We reserve the right to make changes due to progress in process engineering and manufacturing technology.
© by amixon GmbH, Paderborn. Reprinting or transfer to electronic media only permitted after written approval.

amixon® GmbH

Halberstädter Straße 55
D-33106 Paderborn (Germany)

Phone +49 (0) 52 51 / 68 88 88-0
Fax +49 (0) 52 51 / 68 88 88-999
e-mail info@amixon.de

www.amixon.com